

CAT50 & Straight Shank ER16 Collet Chucks

(Balanced to G2.5@15,000 RPM)

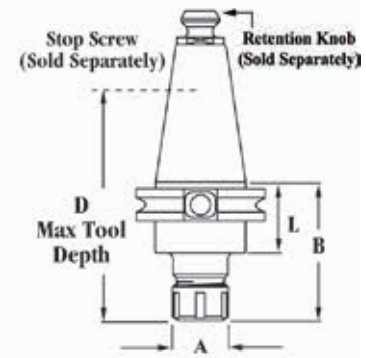

- Small diameter nose well-suited for working in close quarters
- Increased flexibility for milling, drilling, and reaming
- Flush precision collet nut, grips tool close to cutting edge for accuracy and rigidity
- Concentric to .0002" TIR puts tool precisely on spindle center line
- AT3 or better shank taper allows for accurate, rigid toolholder-to-spindle mount
- Wide range collets reduce collet and toolholder inventories
- Fully ground flange and V-groove is easy on tool changers for less spindle and changer maintenance
- Through spindle coolant standard
- [ER16 Collets found on pages 602-603.](#)



CAT50 ER16 Collet Chucks							
Capacity	Taper	A	Gage Length (B)	D	L	Max. Nosepiece Torque	Part #
.020-.393	CAT50	1.259	4.88	3.00	1.38	24 ft lbs	RC5ER164880
.020-.393	CAT50	1.259	6.88	3.00	1.38	24 ft lbs	RC5ER166880

ER16 Straight Shank Collet Extension						
A	B	D	L	Photo	Dimensions	Part #
1.259	7.0	.750	5.9			RSSER16700

ER16 Parts & Accessories			
Description	Photo	Dimensions	Part #
ER16 Replacement Nosepiece			RER16NPA
ER16 Collet Wrench†			RER16W
ER16 Stop Screw			RER16SS
ER16 Stop Screw Coolant Thru			RER16SSC

†Required for assembly.